

PRESS RELEASE

PRESS RELEASEApril 23, 2018 || Page 1 | 3

Clean and Efficient – Fraunhofer ISE Presents Hydrogen Technologies at the HANNOVER MESSE 2018

The interplay between automation and energy technology, IT platforms and artificial intelligence is the focus of the HANNOVER MESSE 2018 being held from April 23-27, 2018. At the renowned international trade fair, the Fraunhofer Institute for Solar Energy Systems ISE presents innovations in hydrogen technology at the joint booth »Hydrogen + Fuel Cells + Batteries« (Hall 27, Booth C58). A highlight at the booth will be the presentation of the GreenTec Award 2018 in the category »Energy« on Tuesday, April 24th at 2 pm.

Functional Laboratory Test Cell for PEM Water Electrolysis

The functional cell is pressure-tight up to 50 bars and serves to analyze membrane electrode units for PEM electrolysis. The integrated reference electrode for the anode and cathode are a unique feature. In newer versions the press force can be selectively adjusted.

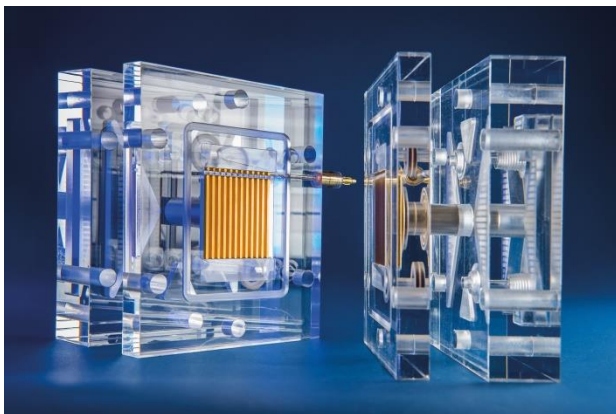

The test cell made of transparent plastic has been successfully implemented in research projects at Fraunhofer ISE for many years. In the photo one sees the current collectors, the gold-plated flow field plates and stamp. ©Fraunhofer ISE

FRAUNHOFER INSTITUTE FOR SOLAR ENERGY SYSTEMS ISE

Municipal Vehicle with Fuel Cell Hybrid Drive

In the ELAAN project, the project partners developed a municipal vehicle with a fuel cell hybrid drive. After analyzing of typical driving profiles and assessing the resulting power performance requirements, it was determined that two 10 kW_{el} fuel cell systems from Fronius, based on a PEM fuel cell stack by Elring Klinger, would be used. The Fraunhofer ISE carried out an extensive sensitivity analysis of the fuel cell stack in order to define the optimal operating conditions for the fuel cell. At the same time, detailed models of the fuel cell system, the stack and essential system components were developed to optimize operating strategies.

<https://www.ise.fraunhofer.de/en/research-projects/elaan.html>

PRESS RELEASE

April 23, 2018 || Page 2 | 3



The electric drive LADOG vehicle with twelve 1 kWh battery modules shall reduce inner-city emissions caused by municipal vehicles. ©Fronius International GmbH

Differential Test Cell for Fuel Cell Components

For the characterization of material and components of low-temperature PEM fuel cells (LT-PEMFC), differential test cells are preferred. Fraunhofer ISE and the company balticFuelCells GmbH developed such a test cell corresponding to the state-of-the-art in science and technology: a minimized temperature gradient of ca. 1 K (operation up to 5 A/cm²), extremely homogeneous and precise pressing of the active area and optimized handling for fast and reliable material and component screening.

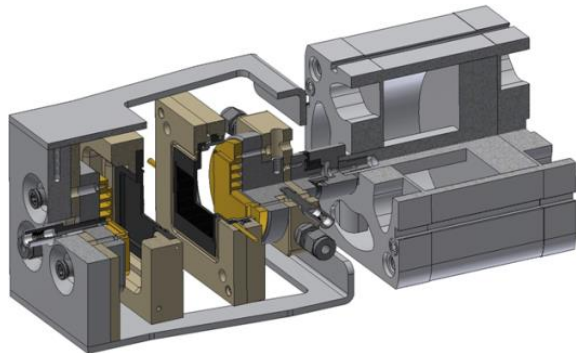

The test cell demonstrates homogenous operating conditions over the active area. The concentration, humidity and temperature gradients are negligible.
©Fraunhofer ISE

FRAUNHOFER INSTITUTE FOR SOLAR ENERGY SYSTEMS ISE

Hydrogen Feed-in Plant to Support Sector Coupling

The model shows the hydrogen generation plant for feed-in to the natural gas distribution grid in the project »Freiburg Communal Energy Network.«

The hydrogen generated by a PEM electrolyzer is fed into the local natural gas grid. A gas buffer storage decouples the electricity and gas grids. The plant control is carried out using complex model predictive control algorithms and live data from the European Energy Exchange (EEX) Day Ahead markets.

PRESS RELEASE

April 23, 2018 || Page 3 | 3



Fraunhofer ISE uses the feed-in plant for testing coupling between the electricity and the gas sectors, new components and modes of operation. ©Fraunhofer ISE

Talks by Fraunhofer ISE Scientists at the HANNOVER MESSE 2018

Ulf Groos: »Choosing the best membrane electrode assembly for your cell design and operation strategy«

Tues., April 24, 2018, 12:20 pm

Stefan Keller: »LADOG- a fuel cell powered municipal vehicle«

Wed., April 25, 2018, 11:20 am

Dr. Robert Alink: »New differential test cell for material evaluation in PEM Fuel Cells«

Thurs., April 26, 2018, 11:20 am

These talks are held in the Technical Forum, Hall 27, at the Hydrogen and Fuel Cell Booth.

The **Fraunhofer-Gesellschaft** is the leading organization for applied research in Europe. Its research activities are conducted by 72 Fraunhofer Institutes and research units at locations throughout Germany. The Fraunhofer-Gesellschaft employs a staff of 25,000, who work with an annual research budget totaling more than 2.3 billion euros. Of this sum, 2 billion euros is generated through contract research. More than 70 percent of the Fraunhofer-Gesellschaft's contract research revenue is derived from contracts with industry and from publicly financed research projects. Branches in Europe, the Americas and Asia serve to promote international cooperation.